

IN
10ths

MM

4b

USE RIBBED PULLEY IN UPPER IDLER LOCATION WHEN ROUTING SUPERCHARGER BELT ON DRIVER SIDE, OR WHEN INSTALLING A/C BRACKET KIT ON NON-SUPERCHARGED APPLICATIONS

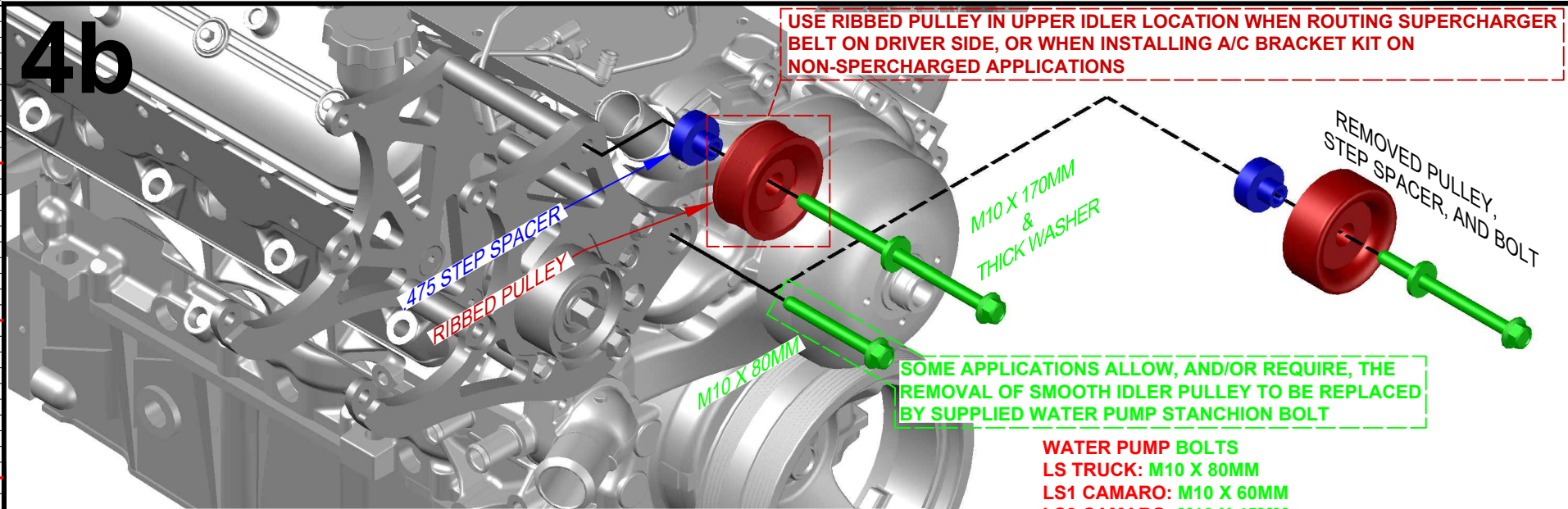

VINTAGE AIR SANDEN 508/709 , GM R4, SANDEN 7176 COMPRESSORS

4b

USE RIBBED PULLEY IN UPPER IDLER LOCATION WHEN ROUTING SUPERCHARGER BELT ON DRIVER SIDE, OR WHEN INSTALLING A/C BRACKET KIT ON NON-SUPERCHARGED APPLICATIONS

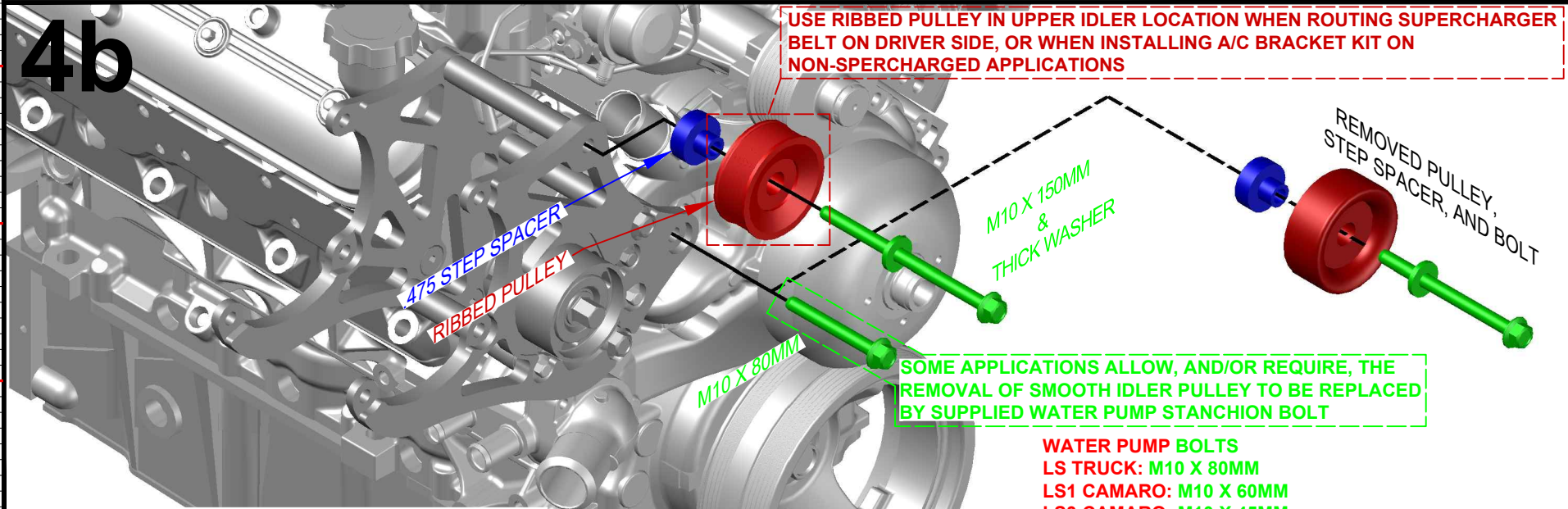

FOUR SEASONS OEM 508 COMPRESSOR

- WATER PUMP BOLTS**
LS TRUCK: M10 X 80MM
LS1 CAMARO: M10 X 60MM
LS3 CAMARO: M10 X 45MM

- WATER PUMP BOLTS**
LS TRUCK: M10 X 80MM
LS1 CAMARO: M10 X 60MM
LS3 CAMARO: M10 X 45MM



**BELT ROUTING FOR
DRIVER SIDE SUPERCHARGED, AND
NON-SUPERCHARGED APPLICATIONS**

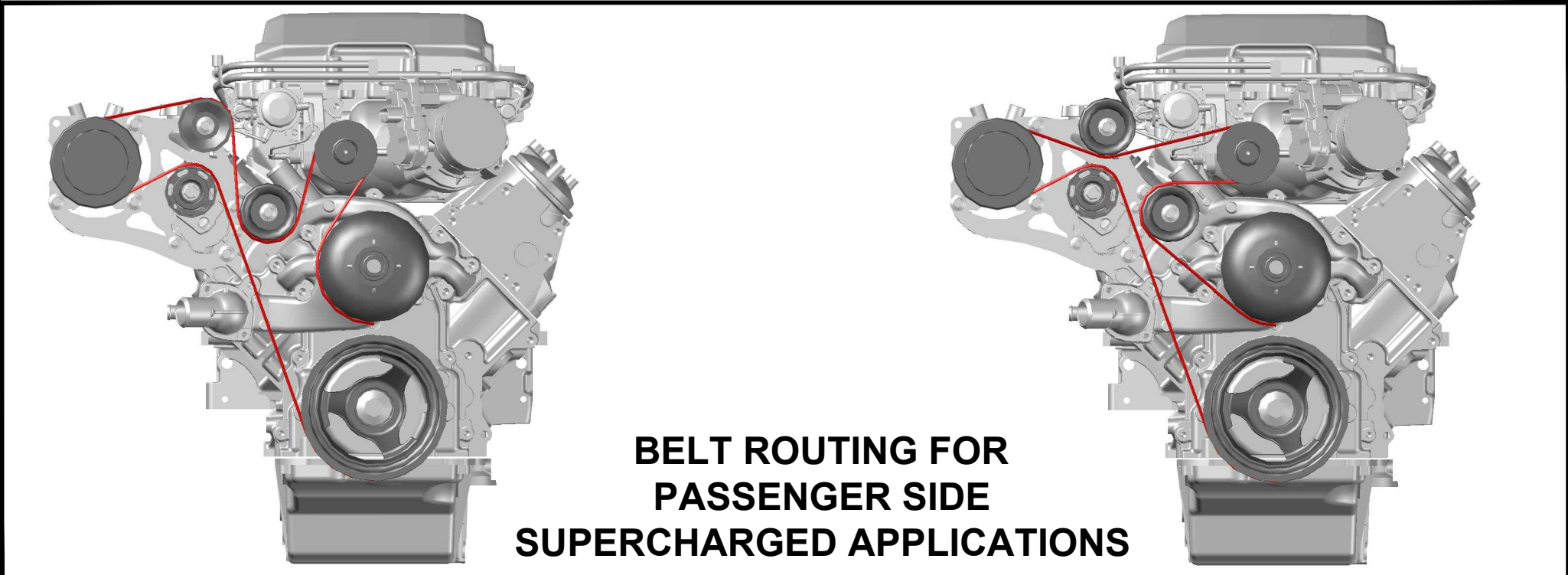
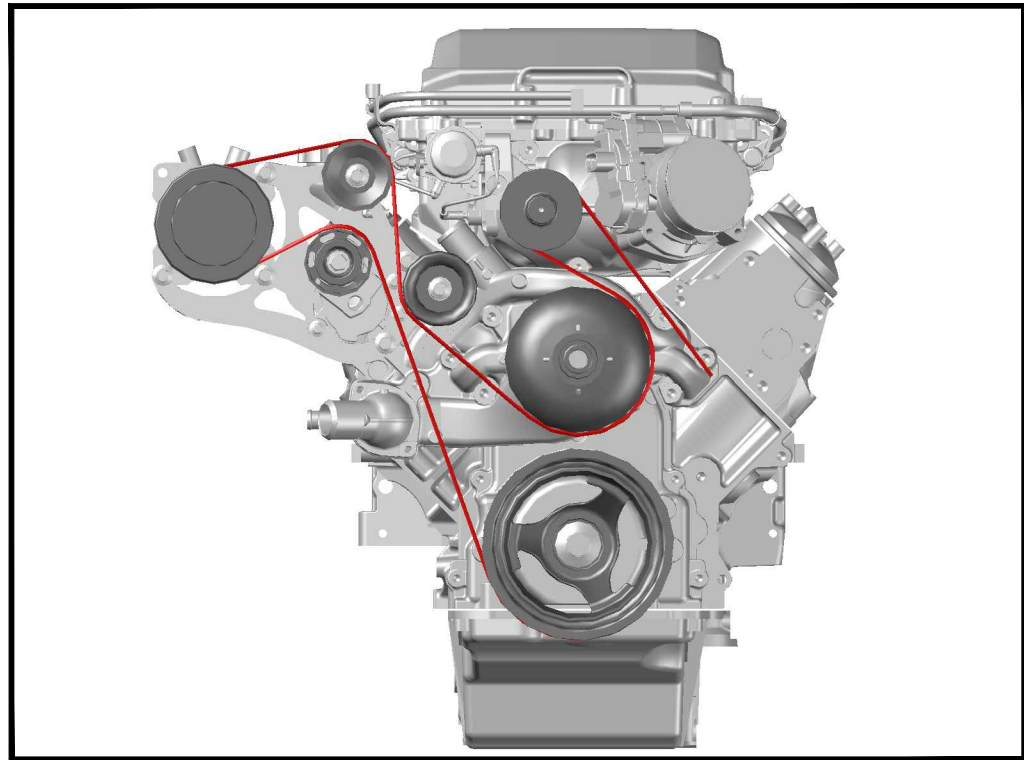

**BELT ROUTING FOR
PASSENGER SIDE
SUPERCHARGED APPLICATIONS**